

Access Technologies Automatic Door Solutions

STANLEY®

SLIDE DOOR
SYSTEMS



SWING DOOR
SYSTEMS



ICU/CCU DOOR
SYSTEMS



BIFOLD DOOR
SYSTEMS



CONTROLS &
ACTIVATION



C. J. RUSH
REVOLVING
DOOR SYSTEMS



SERVICE &
INSTALLATION



STANLEY®





the
world of

STANLEY

®

Access
Technologies



**DURA-GLIDE™/DURA-GUARD™
2000 SERIES**

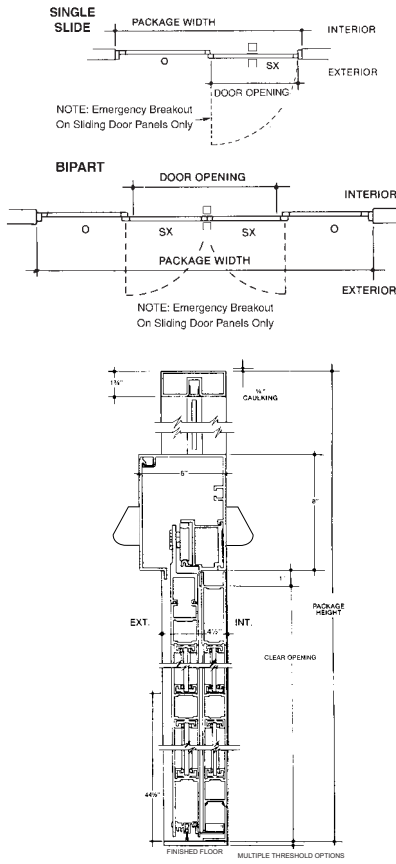

**DURA-GLIDE™/DURA-GUARD™
3000 SERIES**

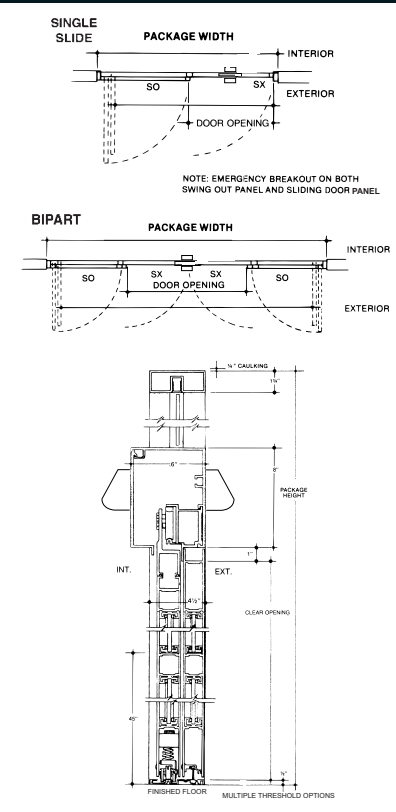

*NOTE: Transom Package Available for both
2000 & 3000 Series*

SLIDE DOOR SYSTEMS



DURA-GLIDE™ 2000/3000 SERIES

Dura-Glide doors combine state-of-the-art micro-processor technology with advanced engineering to provide the safest, most dependable and highest-performance door-systems in the industry.

The Dura-Glide 2000 and 3000 Series are the industry standard for smooth, reliable operation in every application from high-traffic retail locations to upscale professional and institutional settings.

Dura-Glide 2000 and 3000 are certified for both Class 1 and 10 Clean Room applications.

Door packages are custom manufactured to fit your job requirements. For sizes greater or smaller than typical, contact your authorized Stanley Access Technologies Sales Representative.

- HEADER SIZE:** 8" (203mm) high x 6" (152mm) deep
- TYPICAL HEIGHT:** 7'-8" (2.3m), clear door opening of 6'-11" (2.1m)
- TYPICAL WIDTH:** Single Slide: 7' to 9' (2.1m to 2.7m), clear door opening width of 35-1/2" to 47-1/2" (901mm to 1206mm). Bi-Part: 10' to 14' (3m to 4.2m), clear door opening width of 48" to 72" (1219mm to 1828mm)
- TYPICAL DOOR PANEL WEIGHT:** up to 220 pounds each (100kg)
- DRIVE SYSTEM:** 1/4 HP DC motor, gear drive, toothed belt
- CONTROLLER:** microprocessor based, safety logic, watchdog LED
- SENSORS:** 2 for motion (switchable between uni-directional and bi-directional) and 1 Stan-Guard® and doorway holding beam for safety. Stan-Vision™ Digital Video Cameras Optional. Mats, wallplates, radio control optional.
- BREAKOUT:** SX panel on the 2000, SX and SO panels on the 3000
- POWER REQUIRED:** 120 VAC, 5 amps min.
- CODE COMPLIANCE:** UL, cUL, ANSI A156.10, UBC, BOCA, ICBO, NFPA 101



Dura-Glide™ 2000 & 3000 Series Doors:

- Continually monitor door position with microprocessor controller.
- Provide smooth, trouble-free operation with long-lasting cast urethane load-bearing wheels.
- Lock each door in its track with adjustable anti-riser wheels.
- Prevent slippage and uneven closing with toothed drive belt.
- Provide complete threshold protection at all times with advanced motion sensors, Stan-Guard® threshold sensor, and doorway holding beam or Stan-Vision™ video sensors.
- Weather Wise™ switch reduces opening widths on larger door systems to save energy in cold or hot weather.
- Power-operated automatic sliding doors may be used as emergency egress doors because they “break-out” in the direction of egress.
- Microprocessor controllers, sensors and operators available as retrofits to existing doors and older Stanley doors.

Dura-Glide™ Optional Features:

- Stan-Vision™ Digital Surveillance Camera provides safety and motion detection in one sensor as well as security surveillance.
- Access Control lets you add card readers, electric locks, control consoles and panic hardware to limit access to restricted areas.
- Access Control Consoles provide four modes of door operation—Timer, Manual, One-Way and Automatic.
- Electric Solenoid Locking System utilizes a high torque steel spring and tension spring.
- Wind Resistant Damper improves safety and reduces repair costs by withstanding wind gusts up to twice that of a standard door package.
- Transom Packages.
- All-Glass Doors and Sidelights provide added elegance and beauty to upscale architecture.
- Designer/Utility package gives maximum design flexibility with wood, hollow metal, painted or glass doors.
- Class 1 and 10 Clean Room rating for clean rooms and computer centers.
- Profile & Wide Angle Jamb Cams—Low profile jamb mounted camera interfaces with building security systems to provide surveillance at entry and at exit. Identification or surveillance views. Remains powered even if door system power switch is turned off. Up to 4 cameras per power supply. One-way and two-way traffic.
- Integrated Alarm Contacts—High level perimeter security; monitors all door openings; concealed tamper free design; monitoring system compatible; single circuit connection; easy to maintain /cost effective; security professionals approved.
- Recessed Panic Hardware—Optimum security & easy access in emergency situations.
- Uninterrupted Power Supply (UPS)—Backup power supply provides an unmatched level of emergency egress in retail, healthcare & commercial environments.
- Junction Box—Provides termination points for video cables and wires from the door system. Attractive design conceals unsightly connections while allowing easy access for technicians and security professionals.
- Delayed Egress (DE) Exit Device provides a controlled egress for openings which require Panic or Fire Exit Hardware for safe egress. It is a self contained exit device, which when armed will deny exit to unauthorized personnel for 15 or 30 seconds, while simultaneously sounding a local or remote audible alarm. After the 15 (or 30) second delay of egress period the device will function as a standard exit device for safe egress. This solution has been designed to aid in loss-prevention at retail locations by denying egress for a set time period.

Clad Door application, consult with Stanley Representative.



All Glass application, consult with Stanley Representative.



Profile & Wide Angle Jamb Cams

Integrated Alarm Contacts



MC521 CONTROLLER PLATFORM

A single platform for all automatic door systems! This new generation controller is completely re-engineered for both slide and swing door systems. A handheld Palm Powered™ Interface computer sets all door functions including door and motor type, handing, speed, hold-open delay, troubleshooting and more, all with the greatest precision and ease yet. As future product lines expand this controller will continue to simplify installation, training, service and maintenance.



SECURITY OPTIONS

STAN-VISION™ DIGITAL SURVEILLANCE CAMERA THAT AUTOMATES DOORS



- Safety & motion detection in one sensor.
- Continues to detect motion when door is inactive.
- Computer configurable sensor zones.
- Redundant safety zone coverage.
- Built-in diagnostics.
- Ignores parallel traffic.
- Self-adjusts to environmental changes.
- Fail safe operation if camera is obstructed.
- Operates in temperatures ranging from -30° to 130° F.
- Continuous safety coverage even while door is in motion.



RECESSED PANIC HARDWARE

Optimum security & easy access in emergency situations. Flush mounted panic hardware extends a minimum of half the door width. Non-handed, single size push bar accommodates door panel widths from 16" to 54" and integrates into a 4 1/4" muntin bar.

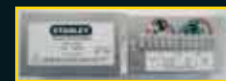

UNINTERRUPTED POWER SUPPLY (UPS)

Backup power supply provides an unmatched level of emergency egress in retail, healthcare & commercial environments. Allows easy access for pedestrians in emergency situations and reduces potential door package damage. Continued operation of automatic doors for up to 1.5 hours in the event of power outages or main power failure.

NEW!

Basic Heavy Duty Features

- Medium Width Stiles
- Welded Door Panel Construction
- Extra Load Wheels
- Kickplates
- Stainless Steel Crash Bars



Advanced Door Operation

- Twin 1/4HP Motors.
- Opens Doors Quickly.
- Avoids Collisions.
- Avoids Structural Damage.
- Avoids Glass Damage.



Wind Resistant Damper

- Reduces door panel damage by controlling panel breakout in strong winds.
- Designed to handle corner zone wind applications.

DURA-GUARD™ HD SERIES



DOOR PACKAGES ARE CUSTOM MANUFACTURED TO FIT YOUR JOB REQUIREMENTS

HEADER SIZE: 8" (203mm) high x 6" (152mm) deep
MAXIMUM SIZES: Bipart - 14' wide (4.2m) x 10'8" (3.3m) high to 16' (4.8m) wide x 8'8" (2.6m) high
 Single Slide - 9' wide (2.74) x 8'8" high (2.66m)
MINIMUM SIZES: Bipart - 12' wide (3.66m) x 7'8" high (2.34m),
 Single Slide - 7'6" wide (2.29m) x 7'8" (2.34m) high
TYPICAL DOOR PANEL WEIGHT: up to 220 pounds each (100kg)
DRIVE SYSTEM: two 1/4 HP DC motors
CONTROLLER: microprocessor based, safety logic, watchdog LED
SENSORS: 2 for motion (switchable between uni-directional and bi-directional) and 1 Stan-Guard® and doorway holding beam for safety. Stan-Vision™ Digital Video Cameras Optional. Mats, wallplates, radio control optional.
BREAKOUT: SX panel on the 2000, SX and SO panels on the 3000
POWER REQUIRED: 120 VAC, 5 amps min.
CODE COMPLIANCE: UL, cUL, ANSI A156.10, UBC, BOCA, ICBO, NFPA 101
CLEAR DOOR OPENING: Bipart: 1/2 package width less 16 1/8" (411mm)
 Single Slide: 1/2 package width less 9" (229mm)

The Dura-Guard™ 2000/3000 Heavy Duty Series Doors are designed to lower costly door repairs resulting from the abuse and collisions with carts and fork lift trucks. Ideal for home centers and warehouses where automatic doors are subjected to daily rigors.

The door is configured to open quickly to prevent collisions. If the doors are hit, rugged construction will minimize damage to the door. Two stainless steel crash bars with rubber isolated shock mounting allow for shock absorption and deflect colliding carts off the door, preventing possible glass damage. In addition the kickplates protect the bottom rail from impact damage and further strengthen the door by "strapping" lead and rear stiles together, which also have tie rods and welded corners.

- Advanced sensors detect carts and fork-lifts, signaling the doors to open sooner.
- Hurricane compliant Dura-Storm versions available to meet stringent Dade County Florida's code requirements.

IMPACT & NONIMPACT VERSIONS

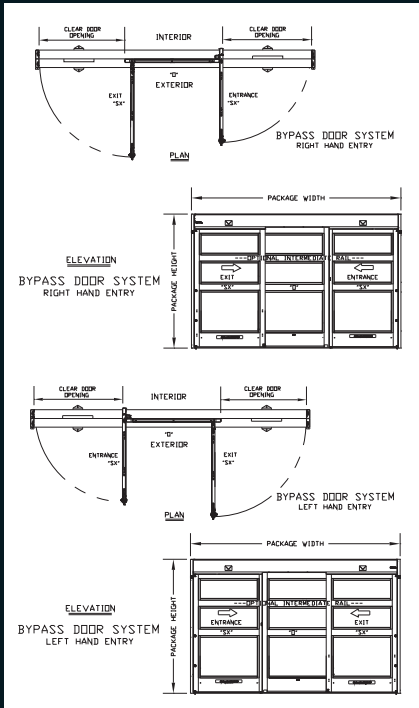

THE BYPASS DOOR SERIES

DOOR PACKAGES ARE CUSTOM MANUFACTURED TO FIT YOUR JOB REQUIREMENTS. FOR SIZES GREATER OR SMALLER THEN TYPICAL, CONTACT YOUR STANLEY SALES REPRESENTATIVE.

HEADER SIZE: 8" (203mm) high x 6" (152mm) deep,
 2 packages included for 12" overall depth
DOOR PACKAGE SIZE:
 Standard: 116" min. width / 220.5" max. width / 7'-8" typical height
 Impact: 122" min. width / 168" max. width / 7'-8" available height
IMPACT OPTION: +/- 70 psf
DOOR PANEL WEIGHT: up to 220 pounds each (100kg)
DRIVE SYSTEM: 1/4 HP DC motor standard
CONTROLLER: microprocessor based, safety logic, watchdog LED
SENSORS: 2 for motion (switchable between uni-directional and bi-directional) and 1 StanGuard® and doorway holding beam for safety. Stan-Vision™ Digital Video Cameras Optional. Mats, wallplates, radio control optional.
BREAKOUT: SX on the Entrance (when fully closed); SX panel on the Exit
POWER REQUIRED: 120 VAC, 10 amps min.
TEMPERATURE RATING: -30F to +130F
CODE COMPLIANCE: ANSI A156.10, NFPA 101, UL, cUL, IBC, ICBO, BOCA, South Florida Building Code, Miami-Dade County Compliance, NOA 03-0605.03



By keeping the entry and exit doors independent, the ByPass system allows for increased and controlled pedestrian traffic flow. A continuous header for both entrance and exit doors simplifies building design. These doors provide a larger clear door opening than standard biparting doors. An impact version with a 70psf wind load rating meets Miami-Dade protocol and is available for structures withstanding hurricane force winds.

DURA-STORM™ HURRICANE IMPACT SERIES

08 42 29/STA
Buyline 0202

**±80 PSF
PRESSURE
RATING**

Total coverage, powerful solutions and designed to handle the pressure, Stanley has developed a broad range of systems that meet the strict requirements of Miami-Dade County. Retail, grocery, home-improvement, high-rise, health care and institutional establishments can all breathe easier, assured that they've met the codes that will protect them. Stanley's Dura-Storm™ sliding automatic door systems meet or exceed all of Miami-Dade, and State of Florida impact and pressure requirements as well as the NFPA (National Fire Protection Association) building egress requirements. Stanley also boasts the highest automatic door pressure ratings in the industry - up to ±80 PSF - with full break out capability and panic bar release.



NEW, PANIC BAR RELEASE OPTION

Typical Maximum Dimensions W X H					
DURA-STORM	Benefits	Made for	PSF Rating	Single Slide Series	Bipart Series
Standard	Durability Low cost of ownership No need for shutters	Retail Department stores Condominiums Grocery Home improvement centers	±56	8' (2.44 m) wide x 7' 8" (2.34 m) high	14' (4.27 m) wide x 7' 8" (2.34 m) high
Steel Reinforced Series 2000/3000	Large clear door openings Reduces door damage Allows largest amount of material movement	Home improvement centers Warehouses Automotive sales Garden centers	±50	9' (2.74 m) wide x 7' 8" (2.34 m) high	16' (4.88 m) wide x 8' 8" (2.64 m) high
Steel Reinforced Series 2000	Large clear door openings Reduces door damage Allows largest amount of material movement Largest height available in the industry	Home improvement centers Warehouses Automotive sales Garden centers	±43.3		14' 11.5" (4.56 m) wide x 10' 8" (3.25 m) high
ByPass™	Allows entry and exit traffic flow from one door High pressure rating	Retail Grocery Markets Office buildings	±70		14' (4.27 m) wide x 7' 8" (2.34 m) high
3000 with Panic Bar Release	Allows emergency egress	Hospitals Healthcare centers Nursing homes	±70		14' (4.27 m) wide x 7' 8" (2.34 m) high
3000 Steel Reinforced with Panic Bar Release	Allows emergency egress release even under hurricane lockdown mode Highest wind pressure resistance in the industry	High-rise buildings Hospitals Healthcare centers	±80		14' (4.27 m) wide x 7' 8" (2.34 m) high

DOOR PACKAGES ARE CUSTOM MANUFACTURED TO FIT YOUR JOB REQUIREMENTS

HEADER SIZE: 8" (203mm) high x 6" (152mm) deep
ByPass™ - 8" (203mm) high x 12" (304mm) deep
DRIVE SYSTEM: 1 or 2 1/4 HP DC motor(s) on one continuous drive belt.
CONTROLLER: microprocessor based, safety logic, MC521-closed-loop control, built-in software watchdog.
MOTION SENSORS: 2 Stanley SU-100 motion sensors, switchable from unidirectional to bi-directional. Optional Stan-Vision™ digital video camera.
SAFETY SENSORS: 1 StanGuard® presence sensor and doorway holding beams. Optional Stan-Vision™ digital video camera.
OPTIONAL EQUIPMENT: Wall plates, radio controls, wind dampers, battery backup, heavy-duty drive system.
BREAKOUT: SX panels on the 2000, SX and SO panels on the 3000 / SX panels on entrance for the ByPass™ (when fully closed, SX on exit).
POWER: 120 VAC, 5 amps max. - 2000 & 3000 / 10 amps max. - ByPass™
TEMPERATURE RANGE: -30° to +130° F
CODE COMPLIANCE: ANSI A156.10, NFPA 101, UL, cUL, IBC, ICBO, BOCA, South Florida Building Code, Miami-Dade Product Control

- Design pressure rating up to ±80 PSF with a safety factor of 1.5x.
- Full breakout for emergency egress.
- Panic bar lockdown release available.
- Single-slide, bipart, or ByPass™ operation for any traffic volume and flow requirements.
- No need for shutters.
- Wind resistant dampers that reduce the risk of injury and repair due to wind-forced doors.
- Restricted air infiltration.
- 9/16" Impact glass in a full range of tints and colors: resists scratches, marks, nicks and abrasions.
- Florida and Miami-Dade County approved.

DURA-STORM™ 2000 / 3000 SERIES & BYPASS™

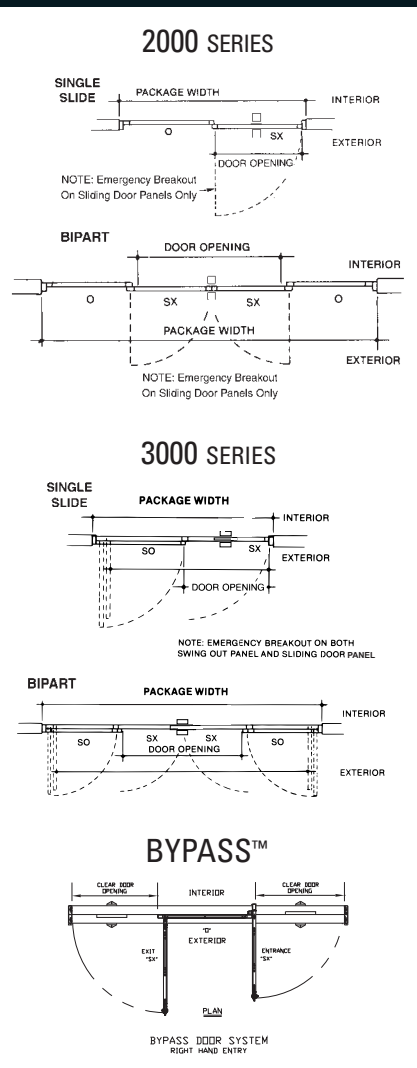



Originally developed for use by a major national retailer, the Storage / Cart Door System is now available for any retailer looking for an improved solution for handling the transport and storage of retail carts and carriages.



From the door hangers to the controls, the heavy duty slider is rugged and dependable. When it comes time to lock up, you're secure.



2000 / 3000 / 5000 DOOR SERIES

- Class 1 & Class 10 Rated
- Microprocessor Controlled
- Advanced Sensor Options
- Controlled Entry

STORAGE / CART DOORS

Designed specifically for the retail environment, the Storage / Cart Door System provides two single slide doors that open and close to facilitate the passage of carts and carriages. This attractive and innovative package provides a unique design alternative for architects and retail design teams by offering a specific solution for carts and carriages away from retail customer traffic.



The single slide door design allows for maximum clear-door-opening providing optimum functionality for the intended application of retail cart storage. The Cart/Storage door provides a solution for the need to improve cart and carriage flow in retail environments.

- Doors slide open to offer access from either the left panel or right panel depending on carriage location.
- Offers push plate automatic activation only.
- Wide door panels make easier cart/carriage egress.
- Four available package widths: 11', 12', 13' & 14'.

INDUSTRIAL DOORS

Industrial Sliders offer heavy duty telescoping door packages that efficiently automate accessways for a wide range of industrial and large retail-type operations. They are individually engineered to provide the same reliability, serviceability and safety as Stanley's Dura-Glide line of lighter-duty sliding doors.

Available in two- and four-panel configurations with widths from 10 to 20 feet and heights from 8 to 12

feet, these doors manage traffic, security and energy conservation with great flexibility. The doors automatically size the opening to the need, spreading wide to accommodate forklifts and other large or bulky traffic, and yet provide a narrower pedestrian passage.

CLEAN ROOM SERIES

Contamination-controlled access for today's highly sensitive technological environments. Industry rated for biotechnology, pharmaceutical, aerospace, medical and dental devices, hospitals, industrial applications and more. Class 1 and Class 10 rated sliding doors are designed and manufactured for conventional or modular construction. Advanced motion and video sensors provide complete protection and contamination controlled entry into clean room areas and vestibules. Microprocessor controller continually monitors door position and specially designed urethane wheels provide smooth, trouble-free operation. Anti-riser wheels lock each door in its track while a fiberglass reinforced toothed drive belt prevents slippage and uneven closing. 5200 &

5300 Telescopic series opens 25% wider than two-panel and four-panel sliding door configurations. Full breakout package allows all panels to swing out and stack to the side for emergency egress.



TELESCOPING DOORS

The special drive system on the 5200 and 5300 Series synchronizes the moving panels so the faster-moving outer panel and slower inner panel reach the jamb at the same time. The 5200/5300 Series door creates a greater clear door opening width while offering the same performance and safety features of our 2000/3000 Series sliding doors.

DOOR PACKAGES ARE CUSTOM MANUFACTURED TO FIT YOUR JOB REQUIREMENTS

HEADER SIZE: 7" (177mm) high x 6" (152mm) deep
TYPICAL HEIGHT: 7'-8" (2.3m), clear door opening of 6'-11-7/8" (2.1m)
TYPICAL WIDTH: 3 panel: 6' (1.8m) to 12' (3.6m), clear door opening width of 35-5/8" (914mm) to 84-5/8" (2159mm)
 6 panel: 7' (2.1m) to 14' (4.2m), clear door opening width of 35-9/16" (902mm) to 91-9/16" (2324mm)
TYPICAL DOOR PANEL WEIGHT: up to 150 pounds each (68kg)
DRIVE SYSTEM: 1/4 HP DC motor, gear drive, toothed belt
CONTROLLER: microprocessor based, safety logic, watchdog LED
SENSORS: Two Stanley SU-100 motion sensors one Stanley Stan-Guard presence sensor and doorway holding beams. Mats, wallplates, radio control optional.
BREAKOUT: lead panel (SX) on the 5200, all panels (SX, SX, SO) on the 5300
POWER REQUIRED: 120 VAC, 5 amps min.
CODE COMPLIANCE: UL, cUL, ANSI A156.10, UBC, BOCA, ICBO, NFPA 101



08 42 29/STA
5200 SERIES Buyline 0202

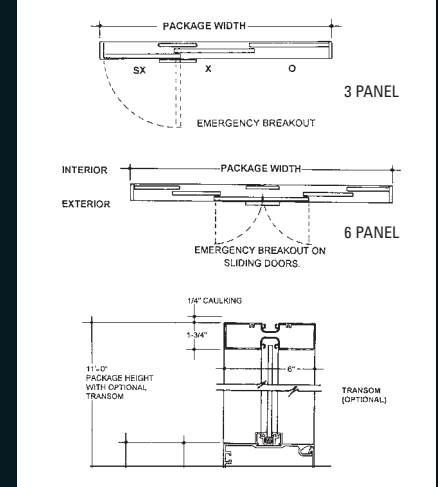

5300 SERIES

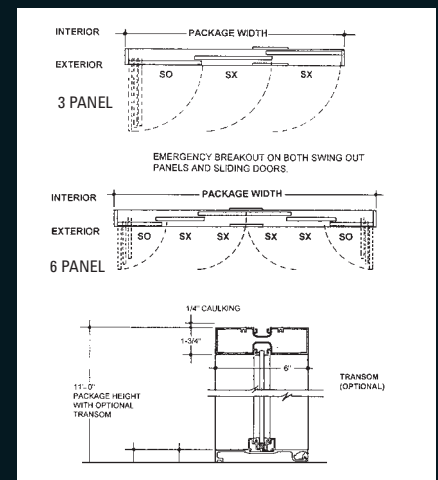

BIFOLD DOOR SYSTEMS

The SB600 Series Automatic Bifolding Door is a proven retrofit solution to give an owner full door automation for two-way traffic where manual swing doors reside today. The bifold has two-panel and four-panel configurations with a variety of opening widths from 4' to 10'. Door panels fold in or out for the most efficient use of space at entrances or exits.

DOOR PACKAGES ARE CUSTOM MANUFACTURED TO FIT YOUR JOB REQUIREMENTS

HEIGHT: 2 Panel: 7'-6" (2.2m) minimum, 9'-2" (2.8m) maximum
 4 Panel: 7'-6" (2.2m) minimum, 8'-6" (2.6m) maximum
WIDTH: 2 Panel: 4' (1.2m) minimum, 6' (1.8) maximum
 4 Panel: 6' (1.8m) minimum, 10' (3m) maximum
TYPICAL DOOR PANEL WEIGHT: up to 100 pounds each (45kg)
DRIVE SYSTEM: Stanley Swing Door Operator
CONTROLLER: Solid state, electronic, safety logic
SENSORS: 2 SU-100 motion sensors, 1 Stan-Guard® (non-fold side) and 1 infrared presence sensor (fold side) for safety
BREAKOUT: all panels
POWER REQUIRED: 120 VAC, 5 amps min.
CODE COMPLIANCE: UL, cUL, ANSI A156.10



About 70% of our bifolding door's package size remains free and clear for passage — a real advantage in tight spaces.



BIFOLD SERIES

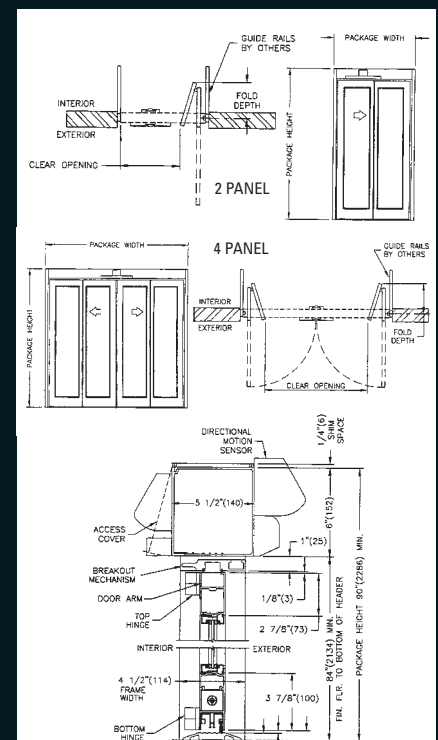

ICU/CCU DOOR SYSTEMS

7000 & 7000 TL (TRACKLESS) ICU SERIES

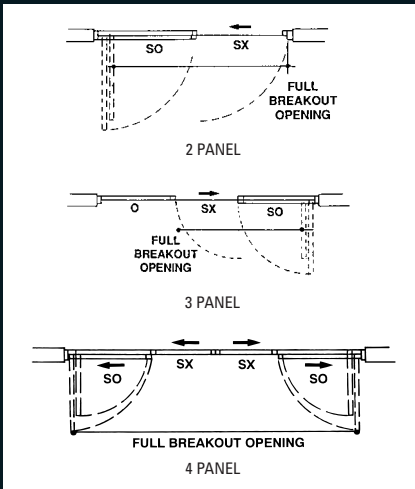

7200 ICU SERIES TRACKLESS

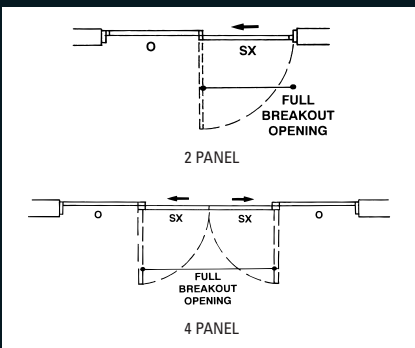

7500 & 7500TL (TRACKLESS) ICU SERIES TELESCOPING

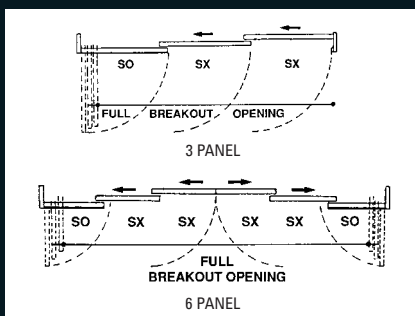

7600 Series ICU Door System

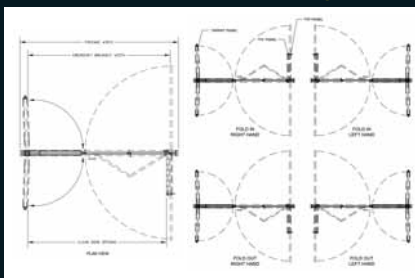

10

Stanley's 7000 Series manual door systems were carefully designed to meet the specific needs of hospital intensive and cardiac care units (ICU/CCU). Their broad glass panels provide an unobstructed view to patients, while leaving patients undisturbed by nearby activity, noise or other intrusions. Available in two-, three- and four-panel packages, the 7000 Series combines the features of both swinging and sliding doors for easy, flexible access to the patient area.



The 7200 Series door package allows for a trackless threshold feature with the ability to break-out the SX panel at any point along the sliding door motion.

Note: Requires O or P Panel.

Optional ICU Smoke & Draft Control Kit with Positive Latching is UL tested and complies with the requirements of the National Fire Protection Association Standard for the Installation of Smoke Door Assemblies (NFPA 105) and the Underwriters Laboratories Air Leakage Tests of Door Assemblies (UL 1784). Smoke and Draft controls are approved for use on 2-panel and 3-panel ICU/CCU Door packages.

The 7500 Series is a telescopic ICU/CCU package creating a greater clear door opening width when sliding the panels. The 7000/7500 Series packages are also available in a trackless version (TL) thus eliminating the threshold that could jar patients or delicate materials. A TL package, unlike the track versions, require the doors to be fully opened and a flush bolt disengaged prior to break-out.

The 7600 Series ICU door system combines the benefits of a swing door and bifolding door in one package. The easy access and hands-free operation facilitates a smooth transition of patients & equipment within highly sensitive areas

DOOR PACKAGES ARE CUSTOM MANUFACTURED TO FIT YOUR JOB REQUIREMENTS

HEADER SIZE: 4" (102mm) high x 4-1/2" (114mm)
TYPICAL HEIGHT: 7'-4" (2.2m), clear door opening of 6'-10 1/2" (2.1m)
TYPICAL WIDTH: 2 Panel: 7' (2.1m) to 9' (2.7m), clear door opening width of 35-1/2" (901mm) to 47-1/2" (1206mm)
 3 Panel: 10-1/2' (3.2m) to 13-1/2' (4.1m), clear door opening width of 35-1/2" (901mm) to 47-1/2" (1206mm)
 4 Panel: 10' (3m) to 14' (4.2m), clear door opening width of 48" (1219mm) to 72" (1828mm)

7000 Series Doors:

- Provide maximum patient-area visibility even when doors are closed.
- Allow flexible access to patient area through single-panel opening or by stacking all panels to one side.
- Guard patients from unwanted noise or other intrusions.
- Features a track or trackless-threshold, consult with Stanley Representative.
- Smoke and draft control available.

7200 Series Doors:

- Advantages of 7000 Series without need for threshold.
- Smoke and draft control available.

7500 ICU Series Doors:

- Telescopic version.
- Largest clear opening width.

7500 ICU FBO:

- Full Breakout Opening

7600 Series ICU Door System

- 105 degree Hold Open Closer - When swing door panel is pushed past 105, the door panel will stay open in either direction allowing for easy access and hands-free operation.
- Adjustable bottom pivots accommodates changes in floor height or type.
- Flush Bolt - Allows for quick & easy release.
- Top Door Guide - Track follows the inside header & guides bifold panels. When released enables full break-out in either direction.



MAGIC-SWING®

MC-521 CONTROLLER

Allows for easier set up and tuning and eliminates wiring a separate interface board. Functions such as door type, motor type, handing, speed, hold-open delay, and more, are all set up using a Palm Powered™ handheld computer.



SENTREX™ SWING DOOR SENSOR SYSTEMS

Sentrex systems use computer-controlled active infrared technology to detect the presence of people or objects in the swing path on both sides of a door. Sentrex systems track the position of the door throughout its swing and adjust its detection zone accordingly. The Sentrex sensor heads use active infrared technology to provide continuous zone coverage whether the door is moving or at rest. Energy patterns in multi-dimensional zones detect people or objects in the area of the door.

To meet the demand for improved safety for swing door applications, Stanley Sentrex™ RS is *the* redundant safety system, providing overlapping presence detection by using both an overhead and an on-door sensor. The Sentrex™ RS is available as an option or as a retrofit upgrade for an existing swing door system.

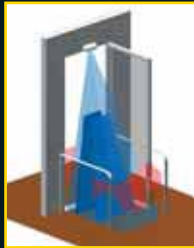

UL FIRE-RATING

Magic-Swing®, Magic-Force™ and Magic-Access® are UL-certified for use as Fire Door Operators on single-swing (or pairs of) fire-rated doors (wood core, hollow metal and steel covered composite type door assemblies) in the U.S. and Canada. Single swing doors must be equipped with electric strikes. Pairs of doors must be equipped with a fire-rated exit device suitable for use with remotely activated retractable latch bolts.

For years, Stanley swing door operators have provided easy access and smooth traffic flow in high-traffic retail, commercial and industrial locations with unbeaten performance and reliability. Magic-Swing® operators continue to set the standard for high reliability and smooth, quiet operation with our proven high-performance mechanics, advanced microprocessor controller and sensor systems that ensure safe operation at all times. Stanley microprocessor controller eliminates the need for moving parts, so it greatly increases uptime and reliability. Door forces and speeds generated during power opening and manual opening, in both directions of swing, as well as spring closing, conform to the standards set forth in ANSI A156.10.

- Powers doors up to: (*) 54" (1371mm) in panel width, 700 pounds (320kg) in panel weight
- Heavy Duty - Extreme environments and abuse
- Full Energy applications (ANSI A156.10)
- Regular and light spring units available
- LCD - Life Cycle Data Recorder



(*) Consult Stanley Authorized Representative for product selection. Door location, mounting conditions and frequency of use may affect product selection.

DOOR PACKAGES ARE CUSTOM MANUFACTURED TO FIT YOUR JOB REQUIREMENTS

HEADER SIZE: 6" (152mm) high x 5-1/2" (140mm) deep
SWING DOOR PANELS: up to 54" (1371mm)
DOOR PANEL WEIGHT: up to 700 pounds (320kg) standard, up to 5000 (2270kg) pounds optional
DRIVE SYSTEM: 1/4 HP DC motor, gear drive, ball screw actuator, rack & pinion
CONTROLLER: microprocessor based, safety logic, watchdog LED
SENSORS: "Sentrex" active infrared presence detector and SU-100 motion sensors, mats and radio controls are available
BREAKOUT: automatic reset (center hung)
POWER REQUIRED: 120 VAC, 5 amps min.
CODE COMPLIANCE: UL, cUL, ANSI A156.10, UBC, BOCA, ICBO, NFPA 101



Magic-Swing® Door Operators:

- Work with every type of sensor we make for maximum design flexibility & convenience.
- Require only simple tune-in adjustments for fast, trouble-free installation.
- Resist wind and stack pressure conditions to maintain smooth, controlled operation.



Optional Features:

- Are available with Sentrex-3™ active infrared safety system.
- Alternative Sensor/Operators include mats, push plates, radio controls & motion sensors.
- Surface Mount Header models afford fast and easy retrofits.
- Choice of complete factory engineered door systems for easy installation and long life even in high-traffic locations.
- Fire Door Package with UL listed equipment.
- Light Spring Operator.
- Monitor door position, and adjust speed at the beginning and end of arc for smooth starts and stops, as well as to comply with ANSI standards.
- Provide safe pedestrian movement at all times with activation and safety sensors.

MAGIC-ACCESS®

The Stanley Magic-Access® low energy operator can automate virtually any swing door; new or existing. Engineered to meet the most difficult applications, Magic-Access® effortlessly provides a full range of automatic door functions to an otherwise manual door. The operating mechanism installs on the door frame in place of a conventional closer and works with virtually any wood, metal or glass door up to 44" wide.

The Magic-Access® offers a variety of operating functions:

- Low energy automatic operation through the use of an activation sensor.
- Operates as a manual door with the option of activation from a pushbutton, wall-switch or card reader.
- Operates as a manual door with the option of the Magic-Touch™ feature—a movement of 3° automatically opens the door.

The state-of-the-art electromechanical operator works in conjunction with a sophisticated electronic controller and a variety of activating devices. The end result: quiet, smooth, automatic door control without compromising building traffic flow and architectural aesthetics. An unsurpassed record of proven performance under the most demanding conditions makes the Magic-Access® the operator of choice.

- Powers doors up to: (*) 42" (1067 mm) in panel width, 125 pounds (57kg) in panel weight
- Low Energy applications (ANSI A156.19)
- Compact unit size
- Retrofit for public access compliance
- Close Speed Control - standard

(*) Consult Stanley Authorized Representative for product selection. Door location, mounting conditions and frequency of use may affect product selection.



DOOR PACKAGES ARE CUSTOM MANUFACTURED TO FIT YOUR JOB REQUIREMENTS

HEADER SIZE: 6" (152mm) high x 4" (102) deep
SWING DOOR PANELS: up to 42" (1067mm)
DOOR PANEL WEIGHT: up to 125 pounds (57kg)
DRIVE SYSTEM: 1/8 HP DC motor, gear drive, "low-energy"
CONTROLLER: Solid state, electronic, with built in "reverse-obstruction" and Magic-Touch® actuation
SENSORS: mats, motion detectors, radio controls are available
BREAKOUT: breakaway door stop available
POWER REQUIRED: 120 VAC, 5 amps min.
CODE COMPLIANCE: UL, cUL, ANSI A156.19, NFPA 101



Magic-Access® Door Operators:

- Comply with all U.S. and Canadian handicap access laws, including ANSI A117.1 and A156.19.
- Open under power and spring close for maximum energy efficiency.
- Work with any metal, wood or glass door; hinged, offset, or pivot center.
- Retrofit conventional doors for a fraction of the cost of a new automatic door.
- Features Magic-Touch™ activation, no mat or sensor needed.
- Operate from any standard 120V AC outlet with no special wiring needed.
- Act as a mechanical closer for manual operation in the event power is shut off.
- React immediately to any obstacle, so an opening door will stop at any point in its swing cycle.

Optional Features:

- Lock Delay
- Sequencing Module
- Power Close Selectable
- Adjustable Time Delay



08 42 29/STA
Buyline 0202

MAGIC-ACCESS® SWING DOOR OPERATORS

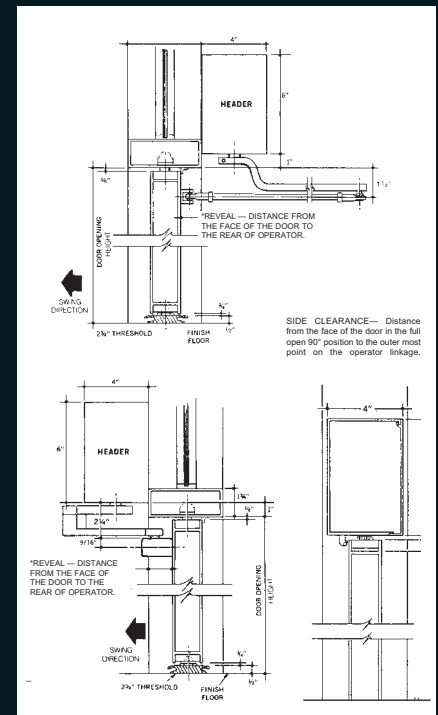

APPLICATION DOOR CONFIGURATIONS

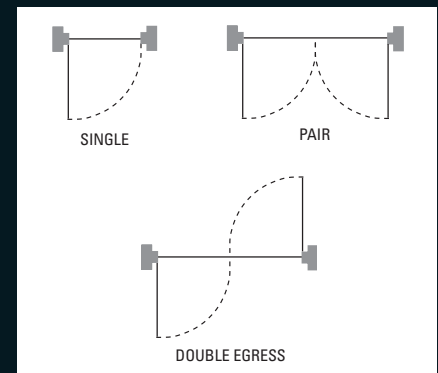

Push or Pull Applications

DOOR TYPES

Hollow Metal or Wood, Glass and Aluminum.





OPTIONAL ACCESSORIES

DELAYED EGRESS

Self contained exit device which armed will deny exit to unauthorized personnel for 15 or 30 seconds while sounding audible alarm.



UNINTERRUPTED POWER SUPPLY (UPS)

Allows easy access for pedestrians in emergency situations and reduces potential door package damage. The UPS provides an unmatched level of emergency egress in retail, healthcare and commercial environments.



STORAGE /CART DOOR SYSTEM

This elegant design solution for carts and carriages provides easy access with maximum clear door opening, developed specifically for the busy retail environment.



RECESSED PANIC HARDWARE

Optimum security and easy access in emergency situations. Non-handed, single size push bar accommodates door panels widths from 16" to 54".



DURA-STORM™ PANIC HARDWARE

This panic bar has been specifically developed to meet or exceed the high standards of Miami-Dade County Codes for emergency egress and may be used in conjunction with our complete line of Dura-Storm Hurricane Impact Series door packages.



MC-521 CONTROLLER PLATFORM

A single platform for our complete line of automatic door systems; the platform has been expanded in 2005 to include both slide and swing door systems making the MC-521 the most versatile controller in the automatic door history.

STANLEY SERIES 500 MANUAL REVOLVING DOOR

The STANLEY Series 500 Manual Revolving Door is an innovative door system designed for use in a wide variety of applications. It is environmentally friendly, helping to improve energy efficiency in buildings and interior comfort while reducing infiltration of dust and dirt into the building entrance.

Features:

- Available in 4 wing design
- Standard diameters; 6'6", 7'0"
- Canopy heights standard 3" low profile.
- Standard finishes - clear or #40 standard bronze anodized.
- Long lasting stainless steel floor ring
- Upper concealed collapsing mechanism
- Bookfold wing position for emergency egress
- Curved laminate glass wall enclosure
- Locks - standard deadbolts
- Overhead speed controls
- Conforms to all North American Building Codes
- One year warranty

REVOLVING DOOR SYSTEMS



c. j. rush industries is a world renowned designer and manufacturer of custom architectural entrance systems. And with the combined efforts of The Stanley Works, the commitment to research, quality craftsmanship, advanced technology, custom fabrication and after-sales service will be enhanced even further.

Revolving doors offer energy-efficient solutions while safely managing large volumes of pedestrian traffic with hands-free operation. In the event of an emergency revolving doors collapse to provide a wide-open and safe passageway outdoors. Their slimline profile maximizes visibility and enhances architectural styling, adding elements of prestige and security to a building's entryway. The air locks are among the industry's tightest, minimizing outside air infiltration, maintaining interior comfort, and reducing heating and cooling costs while keeping noise and dirt to a minimum. Their flexible design and broad selection of materials allow for a near infinite variety of standard and customized styles and finishes. With such a wide selection of materials, features and options, these doors will accommodate virtually any architectural design and will meet any building's specific operational needs.



Revolving Door Features:

- *Narrow line flush glazing door and enclosure sections*
- *Concealed collapsing mechanism and speed control*
- *Concealed fasteners*
- *Bookfold wing position factory set for emergency egress*
- *Conforms to all North American building codes*
- *ASTM E283 for air tightness*
- *Standard and custom models available*
- *Easily removed door wings to provide fast, efficient service*



Revolving Door Options:

- Double wall glass enclosure for air plenum and grilles
- Cladding in stainless, brass or bronze.
- All glass canopy
- Canopy lighting
- Tinted glass (wings and enclosure)
- Curved metal panels in place of glass enclosure
- Curved laminated or tempered glass
- Custom handles
- Custom designed push bars and plates
- Vertical and/or horizontal muntins
- Power assisted or automatic operation
- Sliding dead bolt lock
- Overhead or floor mounted speed controls
- Extended warranty available
- Maintenance & Service contracts available
- Quarter-point closing mechanism
- Quarter segment floor grille



1500 SERIES



Full framed featuring narrow 1 9/16" (40mm) stiles fully weather stripped and integrated to a fluted metal clad centre shaft. With the patented, door wing, pressure release mechanism concealed below the floor and within the canopy ceiling, stile to rail connection is crisp and clean. Various heights of door stiles are available to suit any design requirement. Three-wing or four-wing design.



STANDARD SIZES:
7' 0" (2134mm)
CUSTOM SIZES FROM:
6' 6" (1981mm) to 9' 0" (2743mm) diameter

Features:

- *Narrow line flush glazed door and enclosure sections*
- *Concealed collapsing mechanism and speed control*
- *Concealed fasteners*
- *Bookfold wing for emergency egress*
- *Conforms to all North American building codes*
- *Conforms to ASTM E283 for air tightness*
- *Standard and custom models available*
- *Easily removed door wings to provide fast, efficient service*
- *Curved laminated glass in enclosure (tempered available).*
- *Tempered glass in door wings*

2500 SERIES



All glass - no visible stiles - curved enclosure base rails are recessed flush below the floor, with curved glass glazed flush to the floor. For clean sight lines, a polished stainless steel centre shaft is available. Upper & lower pressure release mechanisms are concealed and directly connected to door rails allowing for clear, unobstructed door lines. Three-wing or four-wing design.



STANDARD SIZE:
7' 0" (2134mm) diameter
or custom diameters to suite job requirements

Features:

- *All glass flush glazed door and invisible enclosure base sections*
- *Concealed collapsing mechanism and speed control*
- *Concealed fasteners*
- *Bookfold wing for emergency egress*
- *Conforms to all North American building codes*
- *Conforms to ASTM E283 for air tightness*
- *Standard and custom models available*
- *Easily removed door wings to provide fast, efficient service*
- *Curved laminated glass in enclosure*
- *Tempered glass in door wings*



3500 SERIES



All glass - no visible door stiles - enclosure base rails are surface mounted to the floor. For clean sight lines, a polished stainless steel centre shaft is available. Upper & lower pressure release mechanisms are concealed and directly connected to door rails allowing for clear, unobstructed door lines. Three-wing or four-wing design.



STANDARD SIZE:
7' 0" (2134mm) diameter
or custom diameters to suite job requirements

Features:

- All glass flush glazed door and invisible enclosure base sections
- Concealed collapsing mechanism and speed control
- Concealed fasteners
- Bookfold wing for emergency egress
- Conforms to all North American building codes
- Conforms to ASTM E283 for air tightness
- Standard and custom models available
- Easily removed door wings to provide fast, efficient service
- Curved laminated glass in enclosure
- Tempered glass in door wings

08 42 29/STA
Buyline 0202



BALANCED DOORS

The differential of interior and exterior air pressure facilitates the opening of these doors in specific site circumstances where climate and/or wind stacking occur. The imposed load on one side opens the door, while the load on the facing side forces the door closed. Less force is required to open the door and door movement is well controlled.

- Concealed overhead door closure
- Pivot points in arms and door points are self-aligning ball and needle combination bearings
- Door bumper spring loaded in track
- Tempered glass doors in a variety of finishes
- Concealed closer arm and track
- Heavy extruded corner and bearing bracket
- Snap on covers with no visible screws
- Options are also available

4500 SERIES

SECURITY REVOLVERS



Whether it's crowd control, controlled access or the highest security applications, security revolving doors range from rugged and utilitarian to refined and aesthetic. For low to moderate security applications, security doors help protect life and property without holding up a building's traffic flow and without pinching a building's security budget. They grant access only to authorized users, without the need for a manned guard station, even during off-hours operation. Security portals provide the ideal solution for high security applications where access requires strict control. With a range of electronic access control and verification device options, a single-entry chamber provides cost-effective, high-security entry and limits access to extremely sensitive areas.



Features:

- Simultaneous two-way traffic
- Programmable Controller
- All type card reader capacity
- Vertical load and/ or floor mat detectors

Options:

- Automatic operation
- Emergency - fail safe features
- Breakaway doors
- Bullet resistant glazing in cage and wings
- All glass profile in cage and wings
- Anodized aluminum, bronze, stainless or painted finishes

STANDARD SIZE:
7' 0" (2134mm) diameter
or custom diameters to suite job requirements



PIVOT/HINGED DOORS

Swing, pivot or hinged doors feature:

- Tempered glass doors in a variety of finishes
- Concealed door closure
- Heavy extruded corner and bearing bracket
- Snap on covers with no visible screws

Options available:

- Centre pivot (concealed)
- Offset pivot (exposed)
- Hinged doors
- 3/4 Hour ULC fire rated door and frame
- Special hardware requirements

rush Architectural Entrance Systems
www.cjrush.com

CJ RUSH GALLERY



rush Architectural Entrance Systems
www.cjrush.com

NATIONAL SERVICE/INSTALLATION

08 42 29/STA
Buyline 0202

Stanley Access Technologies has been the recognized leader in manufacturing, installation and service by the automated door industry for nearly 70 years.

This product leadership allows Stanley to provide a portfolio of service delivery programs that offer the convenience and economy of obtaining all your automatic & manual door maintenance service through a single point of accountability. This common sense approach gives our customers the flexibility to custom design service equipment coverage to meet their varying service needs and budget requirements.

Most importantly, as a service customer, you receive the expertise of the industry's largest and most experienced automatic door service provider. When choosing Stanley you can be assured your equipment is kept in top operating condition, planned maintenance is completed as required, parts replacement meet manufacturers specification and all activity is documented thereby minimizing your liability exposure.

Demand Services

Demand Services is our base service offering consisting of a standard hourly rate and parts replacement at published list prices. If no problems arise you pay nothing for service. *In the event a major repair is required the customer bears the expense.*

PM Only

This service provides a regular, typically twice a year, 14 point factory specified equipment inspection. *In the event you require service between planned maintenance*

intervals, Stanley provides its national network of service resources with no compromise in quality and at competitive rates.

PM Plus

This program provides most of the minor parts required during planned maintenance inspections. It also provides unlimited corrective labor services during agreement coverage hours. *In the event your equipment requires a major part replacement, as a Stanley service customer, you'll receive OEM specified parts at competitive contract rates.*

Comprehensive Service

This program provides planned maintenance with proactive parts replacement and unlimited remedial corrective maintenance services. It also provides performance checks to assure your door system operates as designed. Service reporting and documentation that meets regulatory requirements are also included.

Stanley service programs are the cost effective approach to providing integrated solutions to customer service challenges whether you're local, regional, or national.



Stanley Service Benefits:

- ✓ Multi-year Savings
- ✓ Coverage Flexibility
- ✓ Manufacturers Service Quality
- ✓ Systematic Documentation & Reporting
- ✓ Technical Support & Analysis
- ✓ Expert Parts Replacement & Repair
- ✓ Single Source Accountability



**Customer Care,
Call Toll Free:
1-888-DOOR-444**

Internet Support Services



The Stanley Web Site is your resource for extensive product information and services.

www.stanleyaccesstechnologies.com

Point and click for the following:

- Product Features
- Comparison Guides
- Architectural Specifications
- CAD Drawings
- Full Photo Gallery

Some sections may be password protected — contact your Stanley Access Technologies Sales Representative.

Additional Products & Services



Stanley's SpecCentre® Architectural Services provides optimal solutions from project review to system design to product fulfillment. Architects and owners can confidently work with one source for all their door opening requirements.



The Stanley "Architectural Specifier" contains a photo gallery of Stanley automatic doors, CSI format product specifications and a complete set of drawings which can be easily downloaded into Auto Cad for incorporation into construction documents.

**Rely on the Stanley expertise and experience
gained from thousands and thousands of installations worldwide.**

Stanley Access Technologies designs, manufactures and markets automatic door systems worldwide. For more than 70 years, we have set the global standard for smooth, quiet operation, user safety, design flexibility, quality, reliability and ease of installation. Our service force is North America's largest and most comprehensive network devoted to the installation and maintenance of automatic door systems. This network combines the global resources of Stanley with the unmatched customer responsiveness of local organizations to ensure every door we sell and install provides our customers with worry-free operation.

AAADM American Association of Automatic Door Manufacturers



Customer Care, Call Toll : 01 (246) 46 1-1549

Stanley Access Technologies
Stanley Security Solutions Product Group
Customer Care: 01 (246) 46 1-1549
www.puertas-automaticas-fragval.com.mx

STANLEY®
Security Solutions

