

Thermal Analysis Instruments

# 60 Series



# 60 Series

## Thermal Analysis Instruments

### Millennia Thermal Analysis

SHIMADZU has been pursuing what thermal analysis instruments should be since it developed the DT-1 in 1958, the first differential thermal analyzer in Japan.

The solutions we obtained through research and development are reflected in our products by features such as "Micro DTA", "Multi-channel" and "Stand-alone" design.

These features help our customers solve problems.

SHIMADZU presents the thermal analysis instruments "60 series" in which market needs, learned through research over the years, have been realized which up-to-date technology.

We introduce the 60 series with confidence, as the thermal analysis instruments for the 21st century.



**TMA-60 Series**  
High-performance and  
multi-functional

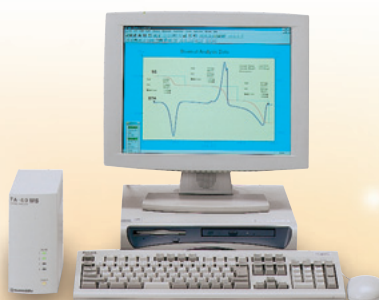

**TA-60WS**  
High-performance and  
multi-functional application compatible  
with latest version of Windows



**DSC-60**  
Equipped standard with  
cooling chamber

Excellent performance/  
price ratio

Full multi-tasking  
capabilities

Compatible with the 50  
series

Multi-channel link up to  
4 units

Compliant with GLP and  
GMP

Compact design for  
space saving

## Contents

P 04 DSC-60

P 10 Automatic TA

P 15 Options

P 06 DTG-60/60H

P 12 Thermal Analysis workstation

P 08 TMA-60/60H

P 14 TGA & DTA



**DTG-60 Series**  
With high sensitivity  
differential balance



**Auto TA**  
Compatible with fully automated measurement,  
from measurement to data analysis

A Fusion of Outstanding  
Technology and Marketing  
60 Series

# DSC-60 DIFFERENTIAL SCANNING CALORIMETER



## Integration of up-to-date Functions and Outstanding Performance

The DSC, an essential instrument for characterizing materials. Development of new high performance and high functionality materials requires always having a higher level of sensitivity and the latest conveniences. Introducing the new DSC system, designed using technology accumulated from years of DSC development.

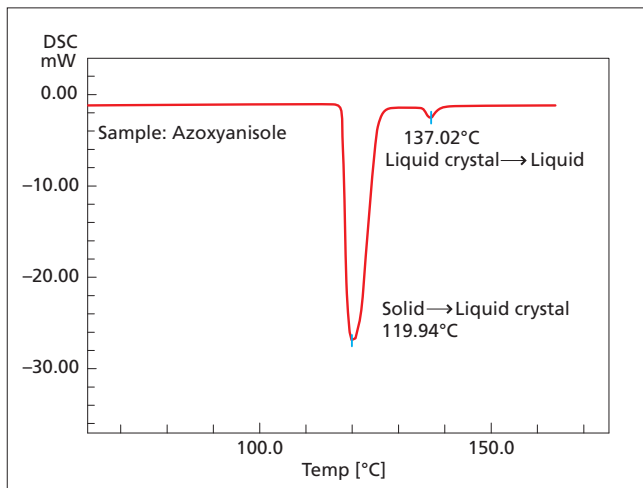

Liquid crystal transition

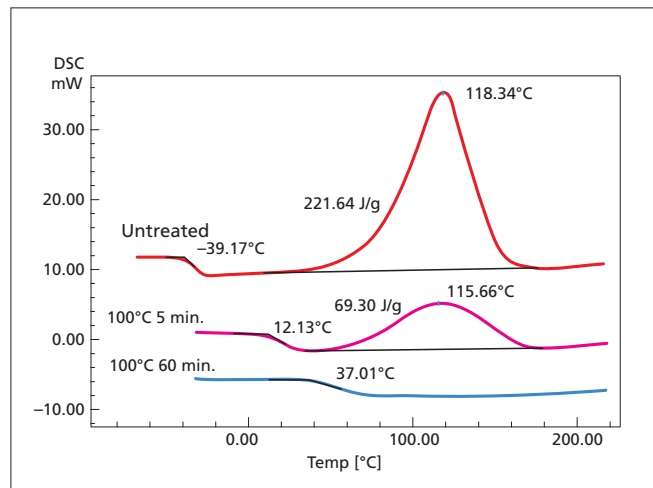

Characteristics of epoxy resin

## Double DSC sensitivity

Along with development of the new detector featuring both heat measurement precision and durability, the DSC peak height has increased to almost double of the conventional DSC technique to accomplish high sensitivity.

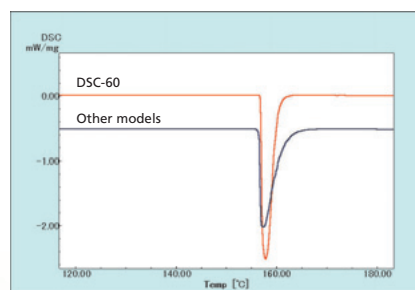

## DSC noise of less than 1 $\mu\text{W}$

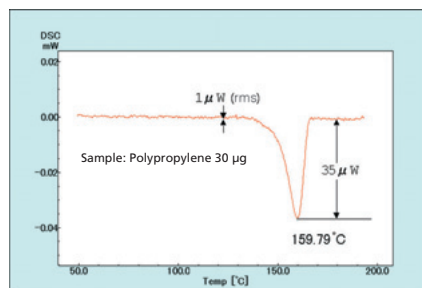

The DSC-60 realizes noise level of less than 1  $\mu\text{W}$  by using the high-resolution A/D converter, reexamining the temperature control theory, and improving thermal conductivity from the heater. Accordingly, a trace of sample can be measured and a slight change can be detected as a large peak.

## New furnace unit of DSC-60

The DSC-60 comes standard with a furnace which is reduced heat capacity and a liquid nitrogen cooling chamber. These features improve the temperature control performance and allow rapid cooling.

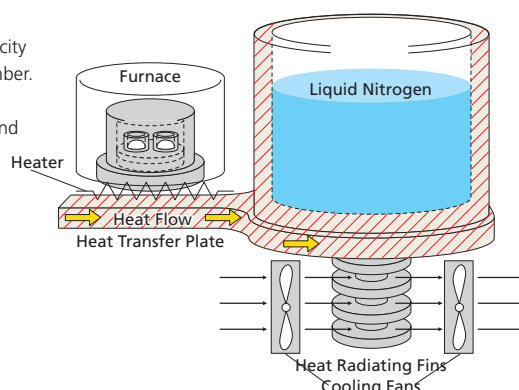

## Fast cooling

The DSC-60 has attained fast cooling by dramatically reducing furnace heat capacity and combining the furnace and the cooling device in one unit. The sample is cooled by 35°C/min. at 0°C and by 10°C/min. at -70°C.

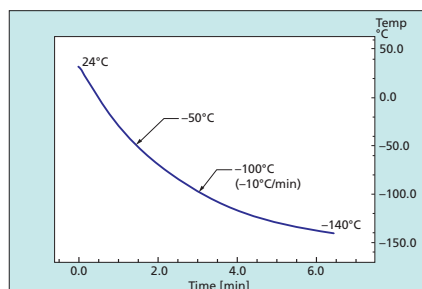

## Precise temperature control

As result of the new development of a new furnace and temperature control unit based on the "heating while cooling" concept, precise temperature control became available. This enables users to create multiple step temperature programs for various applications.

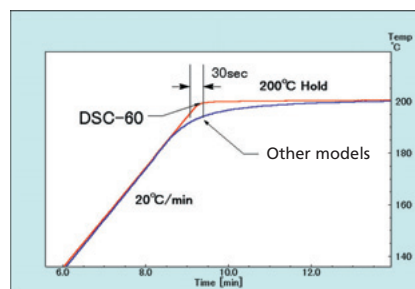

## Sample setting temperature option

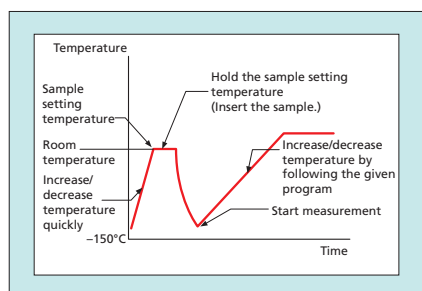

### DSC-60 Specifications

Measurement principle	Heat-flux type
Temperature range	-140 to 600°C (With standard cooling chamber and using liquid nitrogen)
Measurement range	$\pm 40$ mW
Cooling time	Approx. 6 min. (600°C to 40°C using liquid nitrogen)
Noise level	1 $\mu\text{W}$ (rms, when held at 150°C)
Atmosphere	Air and inert gas
Dimensions and weight	W: 320 x D: 500 x H: 290 (mm), 21 kg
Power supply	AC 100 V, 120 V, 230 V 800 VA, 50/60 Hz

When the furnace temperature is below the ambient temperature, it is generally difficult to set a sample pan without causing frost formation on the furnace surface. To solve such inconvenience, the DSC-60 provides a new sample setting temperature option.

# DTG-60/60H SIMULTANEOUS TG/DTA



## Simultaneous TG/DTA improves ease of operation, sensitivity and analytical accuracy of conventional standalone systems.

If flexibility and high performance is needed in various applications, the new DTG-60/60H combines them all: Basic functions required by simultaneous thermogravimetry/differential thermal analysis (TG/DTA) measurements are improved. Atmosphere control is programmable. As in DSC, the TA-60WS provides advanced acquisition, analysis and report functions which ensure comfortable simultaneous measurements.

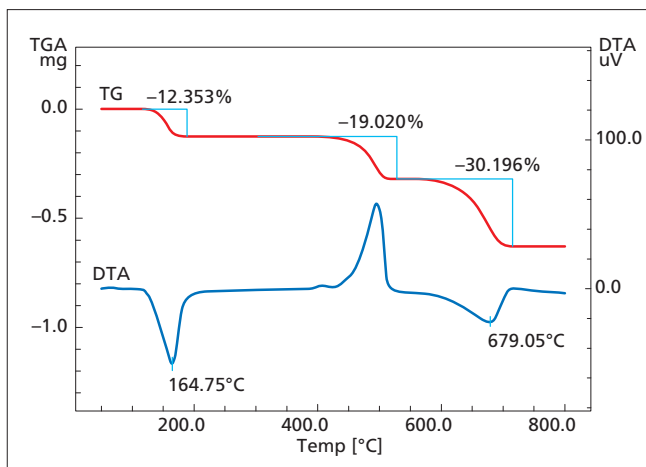

Measurement of CaC<sub>2</sub>O<sub>4</sub>

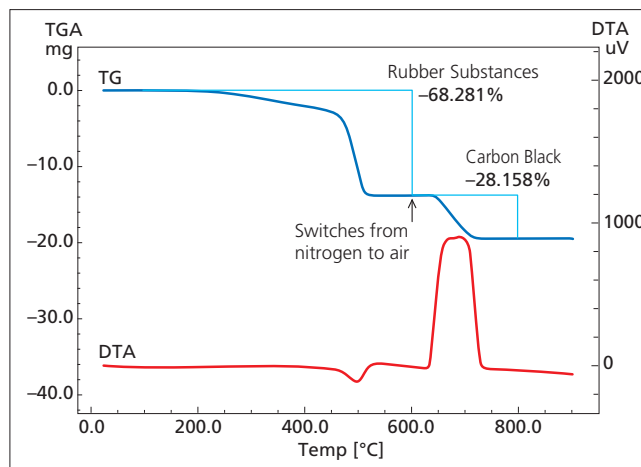

Measurement of carbon black in SBR

## High sensitivity and high precision of balance is equivalent to dedicated single-function instruments

Model DTG-60 has a unique balance mechanism (Roberval mechanism) that prevents changes in sensitivity from factors such as thermal expansion and allows high precision thermogravimetric measurements. Furthermore, the fulcrum used for the balance is made from thin alloy metal strips that have tiny thermal coefficients and are crossed to form an "x" shape. This fulcrum (X-shaped fulcrum) is lightweight and has extremely low friction and resistance. Using this fulcrum configuration allows incorporating a highly sensitive balance and is even highly resistant to vibration.

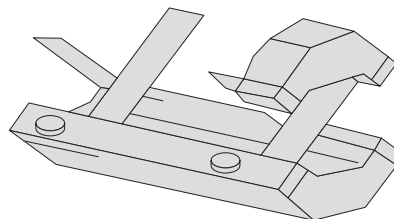

X-Shaped Fulcrum

## Improved baseline stability

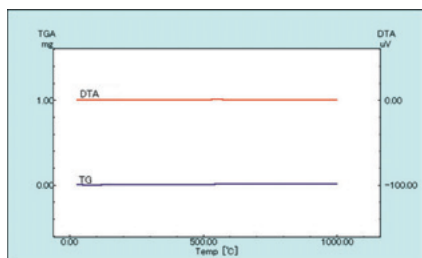

DTG-60/60H provides a true DTA setup. The sample and the reference position are located at the ends of the balance beam. This differential balance system minimizes baseline drifts caused by buoyancy or convection during the heating process, ensuring a stable baseline even at high temperatures.

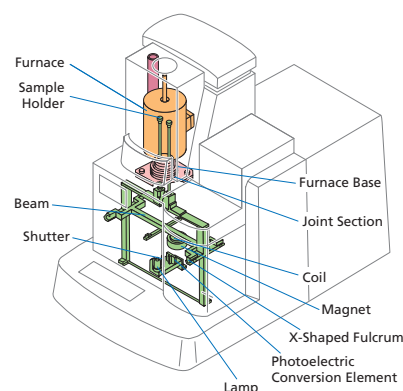

## High sample throughput

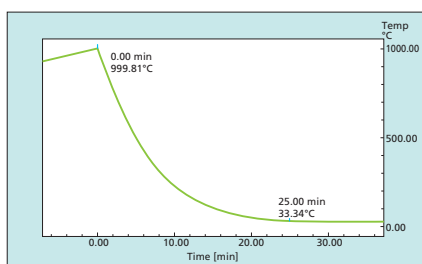

The built-in cooling fan and the low-mass furnace allow very efficient cooling times. After the completion of the measurement, the cooling starts automatically and stops when the furnace has reached a preset temperature. Now the next analysis can be started. Cyclic and cooling runs are under full instrument control.

## Fully controlled atmosphere for various applications

During TG/DTA measurements, qualitative and quantitative analysis, examination of reaction mechanisms and evaluation of heat resistance are performed by studying various reactions and interactions between a sample and special atmospheres. The unique channel structure of the DTG-60/60H offers the solution for these applications. While an inert gas purges the balance, reactive gases are directly connected to the reaction pan. In combination with the FC-60A the measurement is fully software controlled.

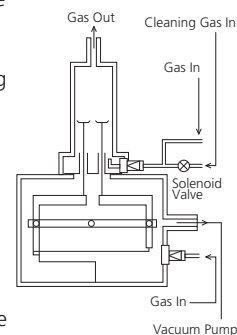

## High sensitivity DTA detectors



The DTA detector of DTG-60/60H is well balanced between contradictory factors "sensitivity" and "resolution". Since symmetrical arrangement of two detectors in the furnace provides excellent temperature distribution, even very small DTA signals such as noise and drift are well matched. Using the convenient plug-in method, the DTA detector can be quickly replaced.

### DTG-60 / DTG-60H Specifications

Balance principle	Parallel guide differential top pan type
Temperature range	DTG-60: Ambient to 1100°C DTG-60H: Ambient to 1500°C
Measurable range (TG)	± 500 mg
Measurable range (DTA)	± 1000 µV
Weight Readability	0.1 µg
Sample quantity	1 g max. in gross weight
Atmosphere	Air and inert gas
Dimensions and weight	W: 367 x D: 650 x H: 453 (mm), 35 kg
Power supply	DTG-60 AC 100 V, 120 V, 230 V 1300 VA 50/60 Hz DTG-60H 1500 VA

# TMA-60/60H THERMOMECHANICAL ANALYZER



## High precision measurement accomplished using simple operations. Even more functions.

The TMA-60/60H thermomechanical analyzer accommodates a wide variety of samples and is able to use various types of measurement methods\* (expansion, elongation, or penetration) to thoroughly evaluate sample characteristics. Newly function, such as the automatic length measurement and safety features, were incorporated into development, resulting in high performance, high functionality and ease-of-use in many dimensions.

\* Model TMA-60 is capable of the total expansion method and Model TMA-60H the differential expansion method.

## Easy operation

Changing between measurement mode is easy and maintainability is outstanding thanks to the use of a bayonet type sample holder that can be attached or removed in one step and plug-in type temperature sensors.

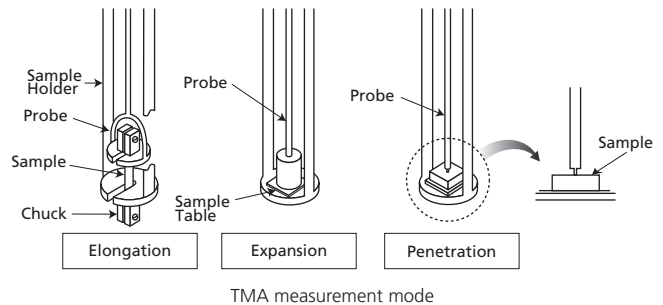

## Probe Safety Function

TMA-60 is programmed with a safety mechanism to prevent sample from sticking to detection probe, such as when heating glass. When displacement exceeds a set range, such as due to sample melting, the measurement is immediately stopped and the load is removed from the sample.

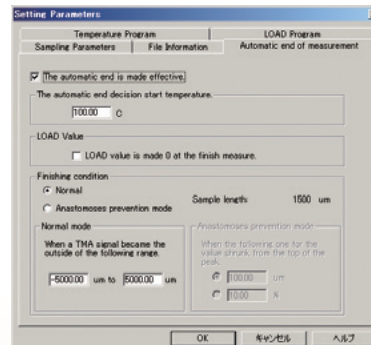

Flexible Parameter Settings

## High precision and Wide dynamic range

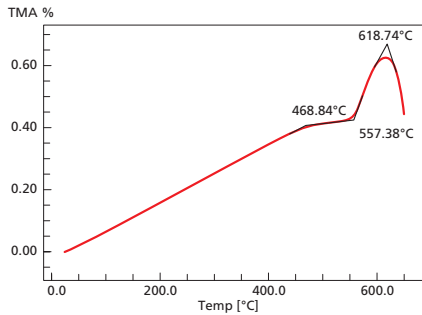

Measurement precision was increased dramatically by using a specialized high precision digital displacement sensor. At the same time, a wide span of  $\pm 5$  mm is possible (twice as much as previous), allowing high precision measurements of deformations ranging from tiny to large.

### Theory and operation of the TMA-60

Thermo mechanical analysis is the measurement of a materials behavior, expansion and/or contraction, as a function of an applied load or temperature. A scan of dimensional changes related to time or load provides invaluable information about the samples mechanical properties. The advanced design of the TMA-60 provides a wide dynamic measuring range through superior integration of detection probe, displacement sensor and force coil.

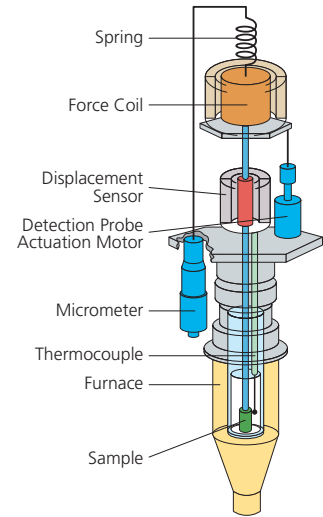

## A Wide Variety of Loading Programs

In addition to applying static loads to samples, constant rate loading, constant rate elongation or cyclic loading programs can be selected. Therefore, it is able to measure stress-strain curves or thermal stresses in film or fiber samples.

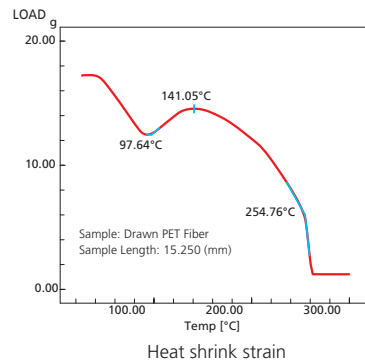

### TMA-60 / 60H Specifications

	TMA-60	TMA-60H
Temperature range	Ambient to 1000°C (Expansion Mode) -150 to 600°C (using LTB-60)	Ambient to 1500°C
Measurement range	Displacement: $\pm 5$ mm, Load: $\pm 5$ N	
Sample load	0 - $\pm 5$ N (500 gf)	
Sample size (Film Samples)	$\varnothing 8$ mm x 20 mm or less (5 mm wide x 1 mm thick x 20 mm long or less)	$\varnothing 5$ mm diameter or less 5 - 20 mm length
Probe/Support tube	Quartz	Alumina
Measurement mode	Expansion, Elongation, or Penetration	Differential expansion
Loading Mode	Constant rate Load up to 50 steps Constant rate Elongation up to 50 steps Shrink Stress Cyclic Load 0.01-1 Hz Frequency	
Atmosphere	Air and inert gas	
Dimensions and weight	W: 367 x D: 624 x H: 880 (mm), 45 kg	
Power supply	AC 100 V, 120 V, 230 V 1000 VA, 50/60 Hz	AC 100 V, 120 V, 230 V 1500 VA, 50/60 Hz

# Automatic TA AUTO DSC & AUTO TG/DTA



## The thermal analyzer with built-in "tweezers" will be the future standard.

The DSC-60A and DTG-60A/60AH is a new automatic TA which defines new standards in autosampler technology. The built-in automatic sampler can easily be operated and programmed, compared to the complicated operation and setup of conventional autosamplers.

Thermal analyzers are not only used for developing materials, but now are increasingly used for quality control purposes. Therefore, more and more users have been demanding automation and improvements to throughput. In the desire to smash the old image of the autosampler (an expensive bulky specialized instrument) even further, our response to user requests was to

begin development of this new Auto TA system. As a result, we completed the DSC-60A/DTG-60A thermal analyzer models with built-in autosampler, developed based on the concept of "Essentially, a thermal analyzer with built-in tweezers". They use the latest software, the cost/performance value is excellent, and they have a space-saving compact design. Either model has the features to satisfy.

### Set up samples for more than 24 hours of analysis

Up to 24 samples can be set up for analysis and additional sample trays can be used to quickly reload the autosampler, providing more than 24 hours of fully automatic analysis at one time.

### The built in autosampler requires no additional space

Externally mounted autosamplers are bulky, occupy much bench space and can cause trouble in operation. However, DSC-60A and DTG-60A/60AH provides a compact built-in autosampler which does not require more space than a stand-alone thermal analyzer.

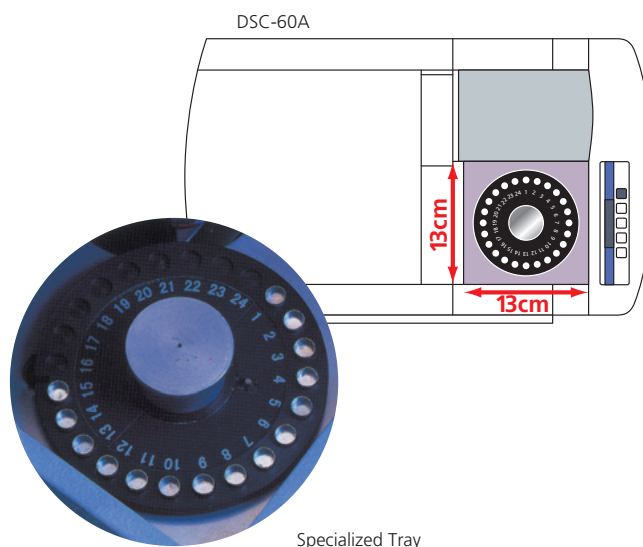

## Fully automatic analysis and report functions

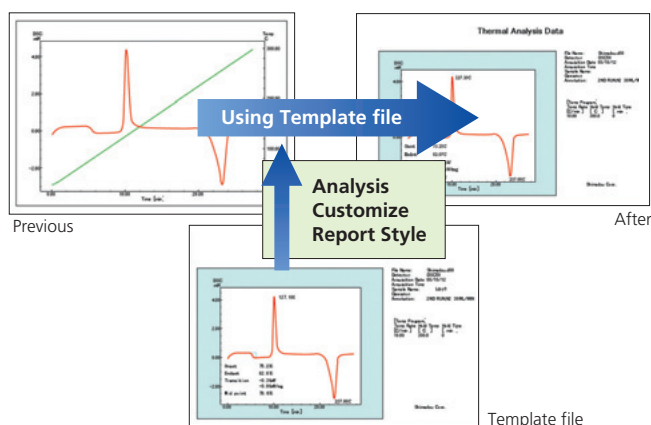

While conventional automatic TA need skilled operators to create complicated macros for operation, DSC-60A and DTG-60A/60AH offers the comfort of a smart macro using a template for automatic analysis and reporting. Once a master file has been stored, DSC-60A and DTG-60A/60AH will perform automatic analysis and printing according to the preset conditions of this template, simplifying the operation to a one-key procedure.

## The autosampler table provides quick status check

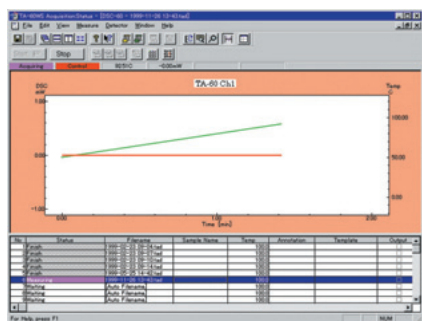

The autosampler table shows the sample names, analytical conditions and templates. The process of the current analysis is monitored. All preset conditions can be changed before the analysis of the samples is started.

## Even reanalysis is performed with a single step

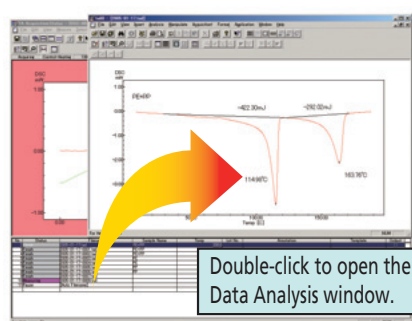

Printed data is automatically recorded. Double-clicking the sample name or file name on the AUS table will display the printed data. Reanalyzing the data or adding analytical sequences is easy, too.

## Enhanced safety functions

The DSC-60A and DTG-60A/60AH provides enhanced safety functions, such as detection of mechanical errors of the arm and the furnace lid, verification of proper setting and return of the sample pan, emergency stop of the trays at abnormal or limit

temperatures, and detection of damaged thermocouples. Analysis can be continued depending on the error condition. Additionally the system will stop temporarily when the furnace or tray cover is opened.

### Sample pan for Autosamplers

346-66963-91*1	Al crimp pans for DSC-60A/DTG-60A ø6 x 3 mm (100 pcs)
346-68518-91*2	Al hermetic pans for DSC-60A ø4.4 x 4 mm (100 pcs), limit pressure 0.3 MPa
346-68796-91*3	Al hermetic pans for DTG-60A/60AH ø6 x 4 mm (100 pcs), limit pressure 0.3 MPa

\*1 Needs SSC-30 and crimp kit (P/N 346-68077-91).

\*2 Needs sealing press and DSC-60A seal kit (P/N 346-68520-91).

\*3 Needs sealing press and DTG-60A seal kit (P/N 346-68797-91).

### Auto TA Specifications

Model	DSC-60A*, DTG-60A*, DTG-60AH*	
Number of positions	24 samples per tray	
Reference	Fix	
Analysis and printing	Automatic analysis and print for template format	
Dimensions	DSC-60A	W:320 x D:500 x H:290 ( mm )
	DTG-60A/60AH	W:367 x D:650 x H:453 ( mm )
Weight	DSC-60A	24 kg
	DTG-60A/60AH	40 kg
Power supply	DSC-60A	AC100 V, 120 V, 230 V 800 VA 50/60 Hz
	DTG-60A	AC100 V, 120 V, 230 V 1300 VA 50/60 Hz
	DTG-60AH	AC100 V, 120 V, 230 V 1500 VA 50/60 Hz

\* Refer to DSC-60 and DTG-60/60H specifications for details, such as measurement range.

# TA-60WS THERMAL ANALYSIS WORKSTATION



## The advanced software in the thermal analysis industry, boasting easy-to-use controls and high performance

The TA-60WS software, compatible with the latest versions of Windows (Vista/XP), can be operated intuitively for smoothly performing everything from measurements to analysis and report output. In addition, it is capable of exporting data to Word, Excel, or other commercial software, using OLE and ASCII conversion functions. User management features and audit trail functions for any parameters ensure that system reliability will increase.

## Multi Channel Control

### Simultaneous control of up to 4 TA units

Up to four thermal analyzer units can be controlled simultaneously, allowing data to be analyzed during measurements. (Snap shot feature)

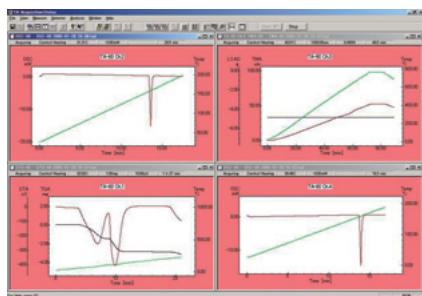

## Wide Variety of Data Analysis Features

### Overlay Data Analysis

This allows analyzing data by overlaying the same or differing types of data (unlimited sets of data). Overlaid data can also be analyzed collectively as a single set.

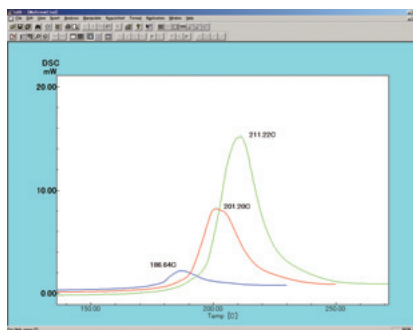

## Compatible with general-purpose software

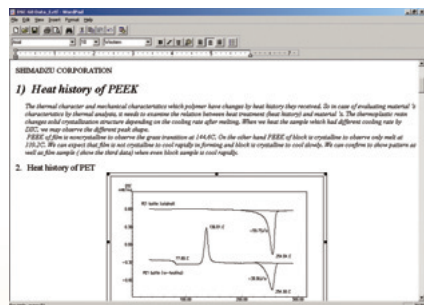

Supporting OLE, the thermal analysis software starts simply by clicking the required thermal analysis data inserted in the MS-WORD or MS-EXCEL file, and gets ready for re-analysis and modification of the data. The reports and study summaries are linked to the inserted thermal analysis data. Thus, when saving the report file, its thermal analysis data is automatically saved to facilitate document management.

Microsoft Word

## GLP and GMP Compliance

Various requirements must be satisfied, such as analytical instrument reliability and electronic record managements, in order to comply with control and regulatory standards such as GLP or GMP. Version 2 the TA-60WS software allows selecting from three operating modes - the standard "Normal" "Security", and "ER/ES" Mode.

Note: Optional "Part 11 Compliance Package" software is required to operate in the ER/ES Mode.

### Prevents unauthorized access via the Login window



Access to the thermal analysis system can be restricted in the "Security" and "ER/ES" modes, by requiring a user name and password for login.

### User management features allow setting operating rights for operators

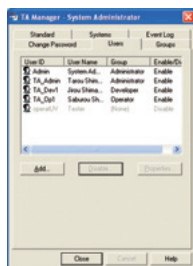

After logging in, operating rights are managed on a group basis. Each user can be assigned to a group based on their job description. Appropriately controlling the operating rights of users provides additional support to managing and operating the system.

### Instrument history is saved as the event log

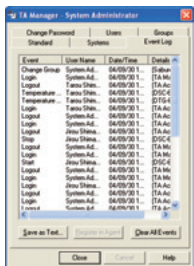

A history of events, such as login, logout and measurement start/stop events, and any changes to instrument parameters is saved as the event log using the audit trail function. If any problems arise with respect to the system or measurement results, this log makes it easy to trace the cause.

### Ensures traceability of measurement results

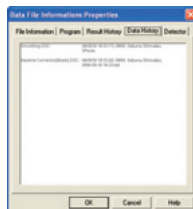

Data files include information about the instrument, such as serial number and calibration coefficient of the instrument, and information about the raw data, such as measurement parameters. In addition, a correction and analysis history for the raw data is recorded in data files, ensuring that traceability is maintained.

## TA-60WS Specifications

<b>Compatible Operating Systems</b>	Windows 7/ Vista / XP
<b>Data Acquisition</b>	Number: Max. 4 units Sampling Interval: 0.1 to 999 seconds
<b>Analysis Parameters</b>	Common to all analysis: Temperature, time, tangent, peak top, signal differential, and peak height DSC and DTA analysis also includes: Heat quantity, glass transition, and automatic DSC peak TG analysis includes above and also: Weight loss, automatic weight loss, loss rate -> temperature TMA analysis includes above and also: Expansion, mean expansion
<b>Data Correction</b>	Group display of analytical results, overlay analysis (same data type, different data analysis, unlimited data, and collective analysis features)
<b>GLP/GMP</b>	Smoothing, baseline correction (blank and temporary lines), temperature correction (above common to all), heat correction (DSC, DTA include the above), total expansion correction, differential expansion correction (TMA includes all the above)
<b>Others</b>	Audit trail features, security features, Part 11 compliance features (optional) OLE features, ASCII conversion features (data, file information, measurement program, analytical results, and correction history), text file save feature

\* Windows, Word and Excel are registered trademarks of Microsoft Corporation (U.S.A.).

# TGA & DTA

## Thermogravimetric Analyzer

### TGA-50 Series

**Micro and Macro Series of Thermogravimetric Analyzers with Advanced Thermobalance Design**



The TGA-50 series is equipped with a lightweight balance mechanism and taut band fulcrum. These have outstanding vibration resistance and provide for stable high sensitivity measurements. These instruments have an extremely wide applicability range, from measuring large-volume samples that cannot be measured using TG/DTA systems, or allowing the use of a variety of sample cell sizes.

#### TGA-50 Series Specifications

Temperature range	TGA-50, TGA-51 : Ambient to 1000°C TGA-50H, TGA-51H: Ambient to 1500°C
Measuring range	± 20 mg, ± 200 mg (TGA-50/50H) ± 20 mg, ± 200 mg, ± 2 g, (TGA-51/51H)
Weight Readability	0.1µg
Sample mass	1 g including tare (TGA-50/50H) 10 g including tare (TGA-51/51H)
Atmosphere	Air and inert gas
Dimensions and weight	TGA-50/50H W: 173 x D: 550 x H: 500 (mm), 23 kg TGA-51/51H W: 173 x D: 600 x H: 540 (mm), 25 kg
Power supply	TGA-50 AC 100 V, 120 V, 230 V 500 VA 50/60 Hz TGA-51/50H 1200 VA, TGA-51H 1500 VA

## Differential Thermal Analyzer

### DTA-50

**High Temperature Heat Flux DTA, provides Quantitative Calorimetry Measurements**



With a unique high sensitivity dumbbell detector, which has an extremely low heat capacity, high sensitivity and excellent versatility, the DTA-50 offers the high sensitivity performance of the DSC system. It is the ideal instrument for characterizing materials such as glass or ceramics.

#### DTA-50 Specifications

Temperature range	Ambient to 1500°C
Measuring range	0.2 to 1000 V / 0.2 mW~
Atmosphere	Air and inert gas
Dimensions and weight	W: 173 x D: 550 x H: 550 (mm), 23 kg
Power supply	AC 100 V, 120 V, 230 V, 1200 VA, 50/60 Hz

# Options

## Sample sealer/crimper

### SSC-30 (P/N 201-52000-90)



Use to crimp sample pans 1 or to seal sample pans 8, 10.

### Sealer adapter for pressure hermetic pan (P/N 222-01450-91)

Used to seal 5 MPa pressure-proof Al pans 10.

### Handpress SSP-10A (P/N 200-64175)

Used to press 5 MPa pressure-proof stainless steel pans 9.

### Sealer adapter for pressure stainless steel hermetic pan (P/N 222-01875-91)

Used to seal 5 MPa pressure-proof stainless steel pans 9.

### TA-60WS software package (P/N 222-10202-91)

Required for off-line analysis.

### Application software for TA-60WS

Partial area analysis program	(P/N 346-68330-92)
Purity determination program	(P/N 346-69100-92)
Specific heat analysis program	(P/N 347-65156-92)
Stress-Strain analysis program	(P/N 347-65160-92)
Kinetics analysis program for TGA	(P/N 347-65164-92)
Kinetics analysis program for DSC	(P/N 347-65168-92)
Dynamic Temperature Control Program	(P/N 347-65148-92)
Part 11 Compliance Package	(P/N 222-10108-92)

## Flow controller

### FC-60A (P/N 346-67995-92: for 120V, -93: for 230V)



The FC-60A flow controller is used to control the flow rate of atmosphere gases (of two channels). Since the gas ON/OFF control is performed according to a temperature program, the atmosphere can be automatically changed during a measurement.

## Automated cooling

### TAC-60i for Shimadzu DSC (P/N 346-68050-92)



Cooling measurement at a temperature of down to  $-50^{\circ}\text{C}$  is enabled simply by connecting a commercially available intracooler (mechanical cooling unit). Since this cooling system does not use liquid nitrogen, it can easily and safely be operated. Using this cooling system together with the DSC-60A enables automatic cooling measurement.

\* Does not include an intracooler  
\* Requires a separate FC-60A controller

## Low-Temperature Furnace

### LTB-60 for TMA-60 Analyzers (P/N 347-65002-93)



Used with a TMA-60 analyzer, it allows measurements between  $-150$  and  $600^{\circ}\text{C}$ . Liquid nitrogen gas is used below room temperature.

## Sample pans

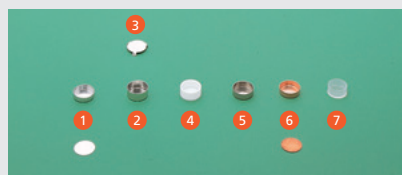

### P/N

1	201-52943	Al crimp pans + lids, $\phi 6 \times 1.5$ (50/set)
2	201-51976	
3	201-56927	Platinum pan, $\phi 6 \times 2.5$
4	201-54321	Platinum lid, $\phi 6$
5	201-53102-84	Alumina pan, $\phi 6 \times 2.5$
6	201-58294-90	Nickel pans, $\phi 6 \times 2$ (50/set)
7	201-54439	Copper pans, $\phi 6 \times 1.5$ (50/set) Quartz pan, $\phi 6 \times 2.5$



### P/N

8	201-53090	Al hermetic pans, $\phi 6 \times 1.6$ (50/set), limit pressure: 0.3 MPa
9	222-02067-92	Pressure-proof stainless steel hermetic pans $\phi 6 \times 5$ (50/set), limit pressure: 5 MPa
10	222-01701-91	Pressure-proof Al hermetic pans $\phi 6 \times 5$ (10/set), limit pressure: 5 MPa



### P/N

11	201-57268-90	Al macro pans, $\phi 6 \times 5$ (50/set)
12	201-53843	Pt macro pans, $\phi 6 \times 5$
13	201-56782-90	Quartz macro pan for TGA (crucible), $\phi 6 \times 5$
14	201-56825-90	Alumina macro pan for TGA (crucible), $\phi 10 \times 14$

## Other pans

### P/N

15	346-66963-91	Al crimp pans and lids for autosampler, $\phi 6 \times 3$ (100/set)
16	346-68518-91	Cooper pans for autosampler, $\phi 6 \times 3$ (100/set)
17	346-68796-91	Pt mesh pan for TGA, $\phi 11 \times 12$

## Installation Requirements

### Dimensions

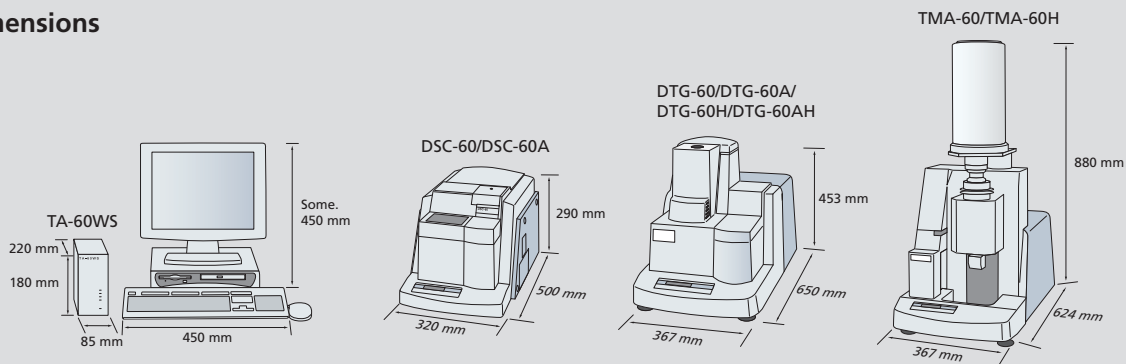

### Analytical balances

To weigh the sample, prepare an analytical balance which allows the precise reading up to 0.01 mg.

### Other

Do not install the device in a place exposed to direct sunlight, a place exposed to direct wind from an air conditioner, a dusty place, a place subject to large vibrations, or a place subject to large temperature fluctuation.

\* Windows is registered trademark of Microsoft Corporation.

### Gas

Purge gas (atmospheric gas to be used)  
Cleaning air tank or air compressor

- Note) • To perform cooling measurement with the DSC-60/60A, dry gas (nitrogen or dry air) is additionally required.
- The DTG-60/60A/60H/60AH provides a reaction gas supply port, in addition to the purge gas supply port.
  - Prepare a tank, pressure reducer and gas flow rate regulator separately.



Shimadzu Corporation  
www.shimadzu.com/an/

Company names, product/service names and logos used in this publication are trademarks and trade names of Shimadzu Corporation or its affiliates, whether or not they are used with trademark symbol "TM" or "®". Third-party trademarks and trade names may be used in this publication to refer to either the entities or their products/services. Shimadzu disclaims any proprietary interest in trademarks and trade names other than its own.

For Research Use Only. Not for use in diagnostic procedures.  
The contents of this publication are provided to you "as is" without warranty of any kind, and are subject to change without notice. Shimadzu does not assume any responsibility or liability for any damage, whether direct or indirect, relating to the use of this publication.